



PERFORMANCE EXHAUST SYSTEM

EPA NOISE COMPLIANT

APPLICATION

YEAR	MODEL
2014	Honda GROM / MSX125

PRODUCT

12120EH220	RS9 SS Slip-On Exhaust with Carbon Fiber Sleeve; Carbon Fiber Endcap
12120EH320	RS9 SS Slip-On Exhaust with Aluminum Sleeve; Carbon Fiber Endcap

- This product is 50-state legal and complies with Federal and State regulations. Any attempts to modify this product will render it non-compliant with Federal law and void warranty. If modified, the vehicle can no longer be used on public roads and can only be used for off-highway closed course competition. In the state of California, it is illegal to modify the emission control system, which includes the fuel injection system of any vehicle.
- You must know how to remove and replace your stock exhaust in order to install this product otherwise have it installed by a professional mechanic. Keep all stock parts from your existing system as some components may be necessary to install your new Yoshimura exhaust depending on the application.
- Read through all instructions before beginning installation. Exhaust system can be extremely hot. Let motorcycle cool down before beginning installation. Always wear hand and eye protection and take precautionary measures to avoid injury.

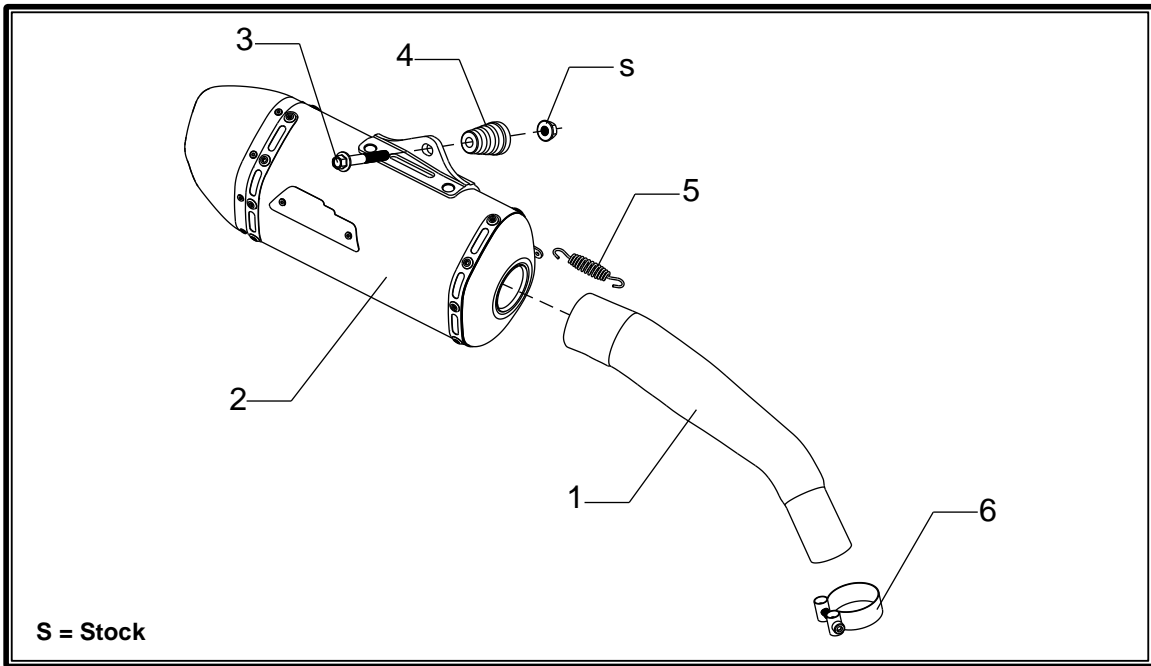

No.	Part #	Description	Qty
1	12120-435	Yoshimura Tailpipe	1
2	**	Yoshimura Muffler Assembly	1
	**	Carbon Fiber Sleeve; CF Endcap	
	**	Aluminum Sleeve; CF Endcap	
3	M8X55H	8mm x 55mm Flanged Hex Head Bolt	1
4	ALS-042	Aluminum Spacer	1
5	RACE-SPX-1	Short Exhaust Spring	1
6	27-49M	Exhaust Clamp	1
**	ST-200	Spring Puller Tool	1
**	17029	Yoshimura Sticker Sheet	1

-TOOLS REQUIRED-

*Metric Socket Set • Combination Wrench Set • Torque Wrench
Metric Allen Wrench Set • Screwdriver*

-REMOVAL-

- 1. Loosen the stock exhaust clamp on the header and muffler connection.**
- 2. Remove the stock muffler heatshield.**
- 3. While securely supporting the stock muffler, remove the two muffler mount bolts and carefully remove the stock muffler assembly.**

-INSTALLATION-

- 1. Slide (27-49M) exhaust clamp over Yoshimura tailpipe.**
- 2. Carefully install Yoshimura muffler/tailpipe assembly over the stock header outlet.**
- 3. Secure Yoshimura muffler to rear muffler mount using the (M8X55H) bolt and (ALS-042) aluminum spacer in conjunction with the stock muffler mount nut. See diagram for proper orientation and order of hardware.**

Note¹: The stock exhaust gasket will not be used with the Yoshimura slip-on exhaust system.

Note²: It may be necessary to remove the exhaust spring to rotate muffler and tailpipe independently to achieve desired alignment.

Note³: Forward muffler mount will not be used.

- 4. Torque muffler mount bolt to factory specification.**
- 5. Re-install exhaust springs if removed in Step 3.**
- 6. Torque exhaust clamp to 13.5 Nm. (1.3 kg-m, 10 lb-ft)**
- 7. Fitment check and Notes.**
 - a. Before starting motorcycle, check for proper clearance between new exhaust system and rear suspension (i.e. tire, swing-arm, brake, rear shock, engine, and etc.) If any problem is found, please carefully follow through the installation steps again. If problem still persists, please call Yoshimura Tech Department at (800) 634-9166 / in CA (909) 628-4722.**
 - b. It is recommended that the muffler and tailpipe be wiped down with rubbing alcohol to remove oil and fingerprints. This will help prevent tarnishing of the finish after the exhaust is heated up.**
 - c. Note: After starting motorcycle, it is normal for new exhaust system and muffler to emit smoke until oil residue burns off.**

NOISE EMISSION WARRANTY

Yoshimura warrants that this exhaust system, at time of sale, meets all applicable U.S. E.P.A. Federal noise standards. This warranty extends to the first person who buys this exhaust system for purposes other than resale, and to all subsequent buyers. Warranty claims should be directed to Yoshimura R&D of America, Inc.
5420 Daniels St. Chino, CA 91710 | Tel (800) 634-9166

TAMPERING PROHIBITION

Federal law prohibits any modification to this exhaust system which causes the motorcycle to exceed the Federal noise standard. Use of the motorcycle with such a modified exhaust system is also prohibited.

Acts likely to constitute tampering include removal or puncturing the muffler, baffles, header pipes, or any other component which conducts exhaust gases.

WARNING: This product should be checked for repair or replacement if the motorcycle noise has increased significantly through use. Otherwise, the owner may become subject to penalties under state and local ordinances.